

4/20/2010 10:10:31 AM T:\13259B Calif High Speed Rail\CADD\Directive Drawings\1.1.10 - Structure Gauge\1.1.10-A.dgn

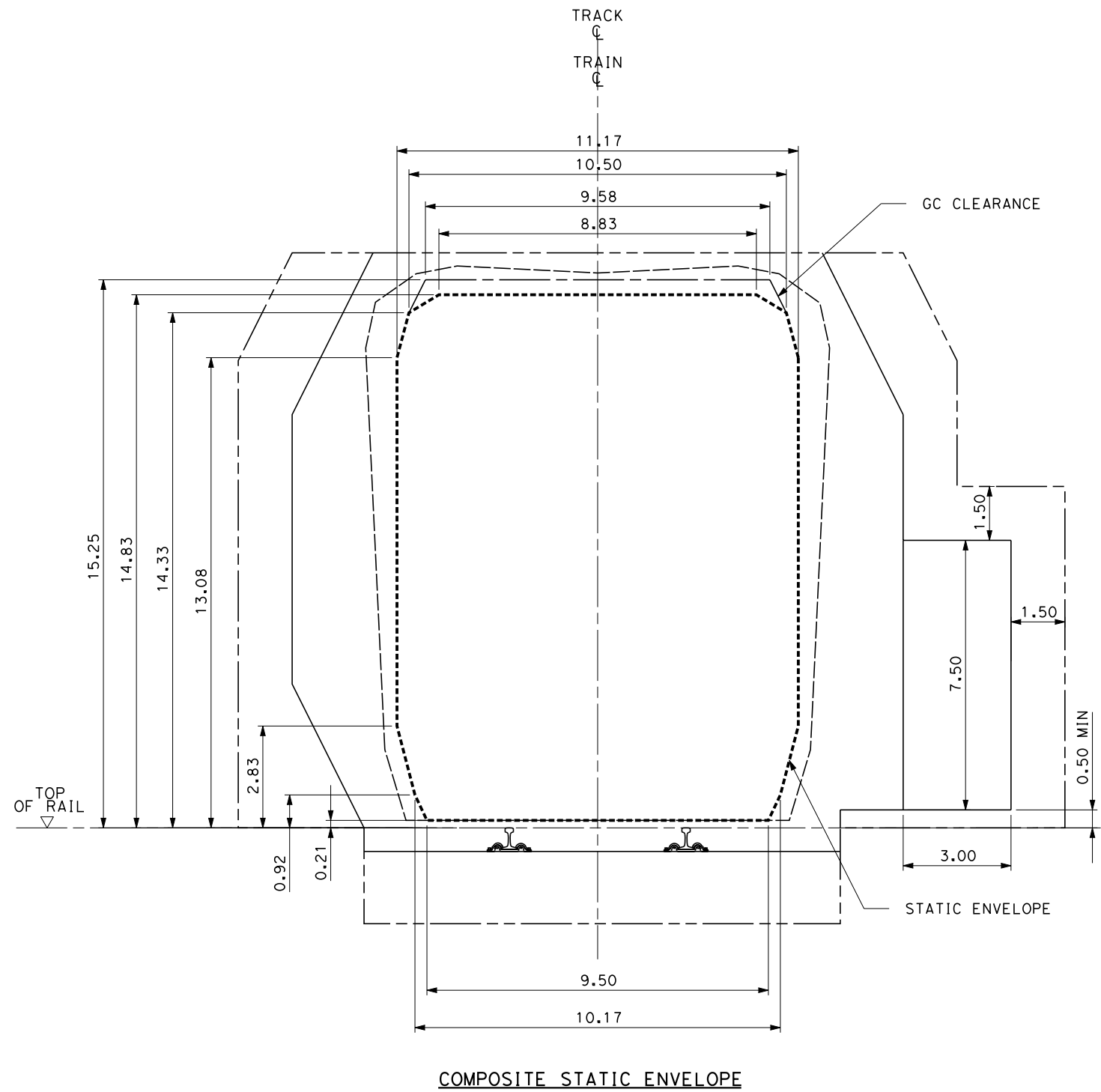

COMPOSITE STATIC ENVELOPE

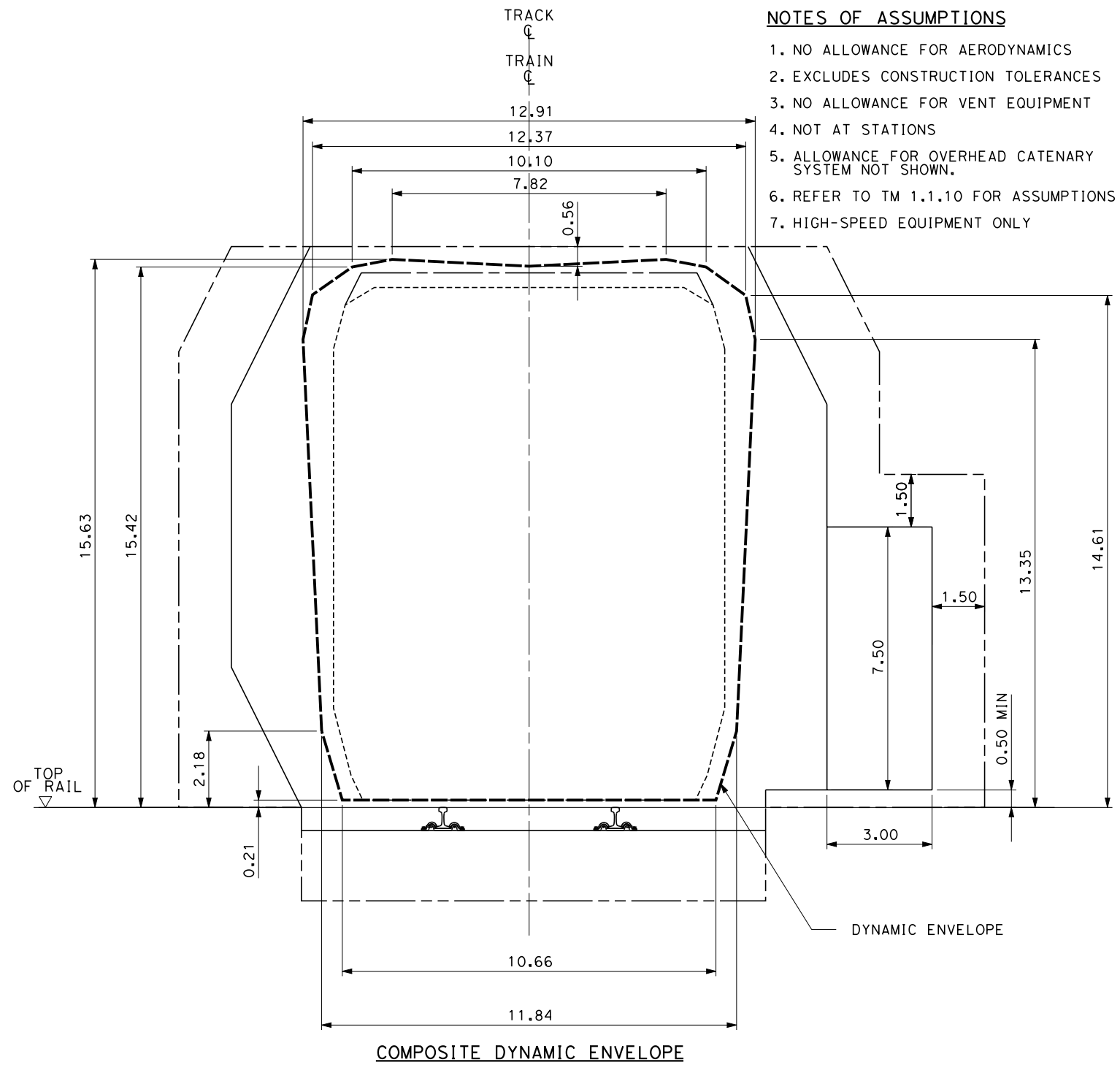

COMPOSITE DYNAMIC ENVELOPE

- NOTES OF ASSUMPTIONS**
1. NO ALLOWANCE FOR AERODYNAMICS
 2. EXCLUDES CONSTRUCTION TOLERANCES
 3. NO ALLOWANCE FOR VENT EQUIPMENT
 4. NOT AT STATIONS
 5. ALLOWANCE FOR OVERHEAD CATENARY SYSTEM NOT SHOWN.
 6. REFER TO TM 1.1.10 FOR ASSUMPTIONS
 7. HIGH-SPEED EQUIPMENT ONLY

LEGEND

- COMPOSITE STATIC ENVELOPE, EXCEPT TSI GC AT TOP
- TOP OF TSI GC STATIC ENVELOPE
- COMPOSITE DYNAMIC ENVELOPE
- FIXED EQUIPMENT ENVELOPE
- STRUCTURE GAUGE



| REV | DATE | BY | CHK | APP | DESCRIPTION |
|-----|------|----|-----|-----|-------------|
| | | | | | |
| | | | | | |
| | | | | | |

DESIGNED BY
G. HARRIS
DRAWN BY
D. SOLTERO
CHECKED BY
J. THOMPSON
IN CHARGE
J. CHIRCO
DATE
04/16/10



CALIFORNIA HIGH-SPEED TRAIN PROJECT

COMPOSITE VEHICLE
STATIC AND DYNAMIC TRACK
TANGENT TRACK

CONTRACT NO.
13259
DRAWING NO.
TM 1.1.10-A
SCALE
1/2"=1'-0"
SHEET NO.
1 OF 4

4/20/2010 10:12:04 AM T:\13259B Calif High Speed Rail\CADD\Directive Drawings\1.1.10 - Structure Gauge\1.1.10-B.dgn

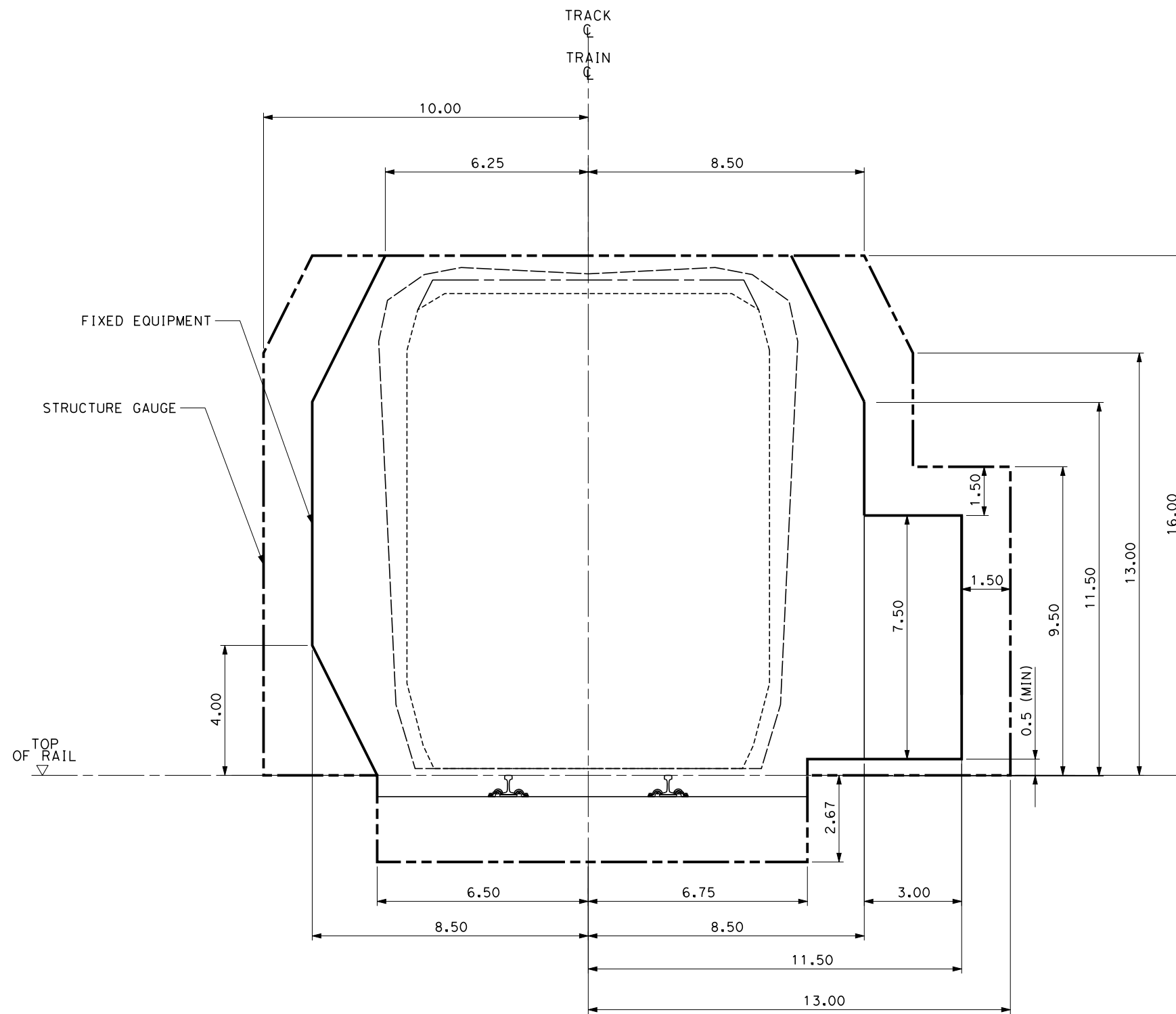

FIXED EQUIPMENT ENVELOPE AND STRUCTURE GAUGE

LEGEND

- COMPOSITE STATIC ENVELOPE, EXCEPT TSI GC AT TOP
- TOP OF TSI GC STATIC ENVELOPE
- COMPOSITE DYNAMIC ENVELOPE
- FIXED EQUIPMENT ENVELOPE
- STRUCTURE GAUGE



NOTES OF ASSUMPTIONS

1. NO ALLOWANCE FOR AERODYNAMICS
2. EXCLUDES CONSTRUCTION TOLERANCES
3. NO ALLOWANCE FOR VENT EQUIPMENT
4. NOT AT STATIONS OR TUNNELS
5. ALLOWANCE FOR OVERHEAD CATENARY SYSTEM NOT SHOWN.
6. REFER TO TM 1.1.10 FOR ASSUMPTIONS
7. HIGH-SPEED EQUIPMENT ONLY

| REV | DATE | BY | CHK | APP | DESCRIPTION |
|-----|------|----|-----|-----|-------------|
| | | | | | |
| | | | | | |
| | | | | | |
| | | | | | |

DESIGNED BY
G. HARRIS
DRAWN BY
D. SOLTERO
CHECKED BY
J. THOMPSON
IN CHARGE
J. CHIRCO
DATE
04/16/10



CALIFORNIA HIGH-SPEED TRAIN PROJECT

COMPOSITE VEHICLE
FIXED EQUIPMENT ENVELOPE AND STRUCTURE GAUGE
TANGENT TRACK

| |
|----------------------------|
| CONTRACT NO. 13259 |
| DRAWING NO. TM 1.1.10-B |
| SCALE 1/2"=1'-0" |
| SHEET NO. 2 OF 4 |

4/20/2010 10:14:50 AM T:\13259B Calif High Speed Rail\CADD\Directive Drawings\1.1.10 - Structure Gauge\1.1.10-C.dgn

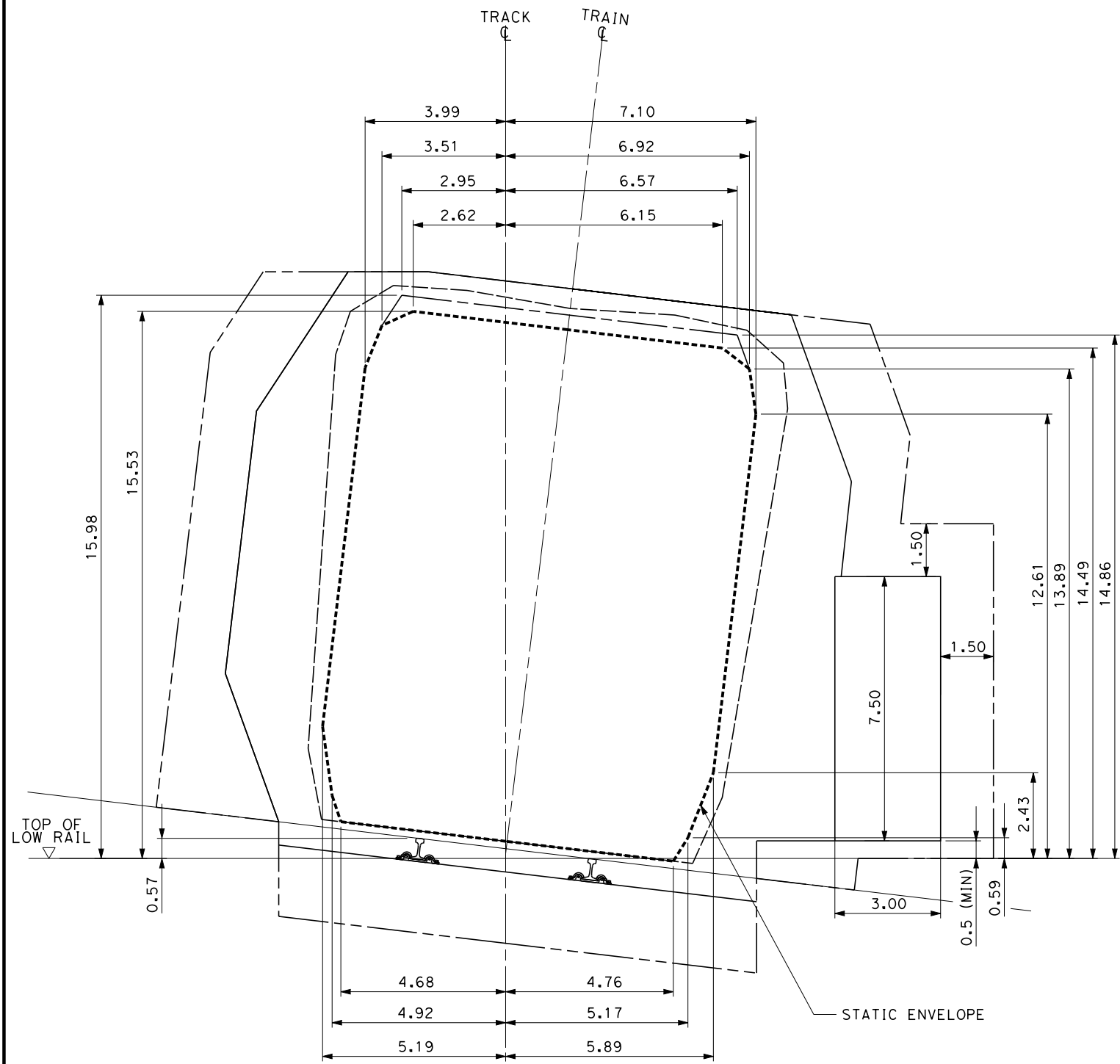

COMPOSITE STATIC ENVELOPE

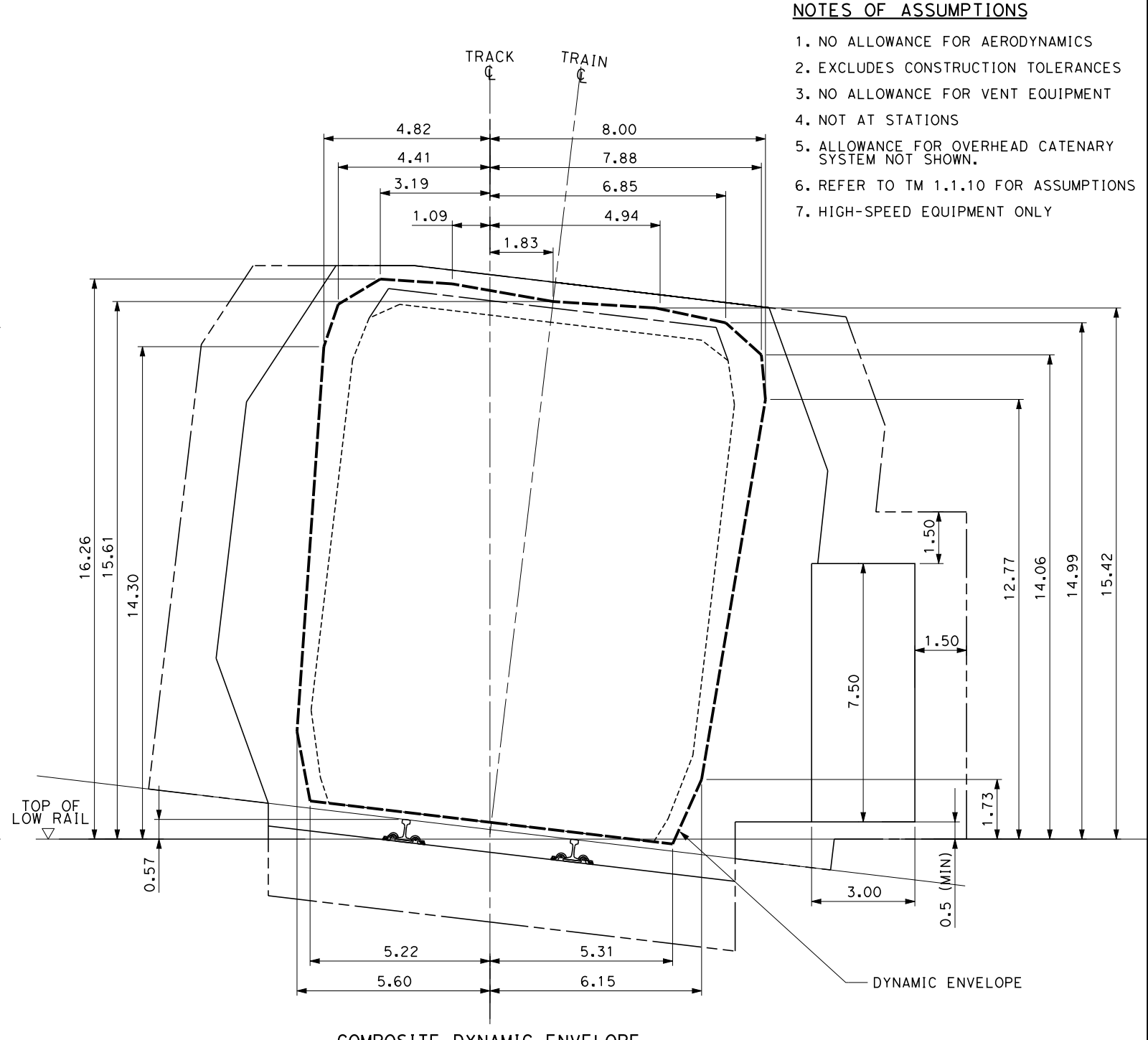

COMPOSITE DYNAMIC ENVELOPE

- NOTES OF ASSUMPTIONS**
1. NO ALLOWANCE FOR AERODYNAMICS
 2. EXCLUDES CONSTRUCTION TOLERANCES
 3. NO ALLOWANCE FOR VENT EQUIPMENT
 4. NOT AT STATIONS
 5. ALLOWANCE FOR OVERHEAD CATENARY SYSTEM NOT SHOWN.
 6. REFER TO TM 1.1.10 FOR ASSUMPTIONS
 7. HIGH-SPEED EQUIPMENT ONLY

LEGEND

- COMPOSITE STATIC ENVELOPE, EXCEPT TSI GC AT TOP
- TOP OF TSI GC STATIC ENVELOPE
- COMPOSITE DYNAMIC ENVELOPE
- FIXED EQUIPMENT ENVELOPE
- STRUCTURE GAUGE

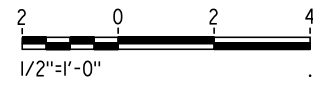

| REV | DATE | BY | CHK | APP | DESCRIPTION |
|-----|------|----|-----|-----|-------------|
| | | | | | |

DESIGNED BY
G. HARRIS
DRAWN BY
D. SOLTERO
CHECKED BY
J. THOMPSON
IN CHARGE
J. CHIRCO
DATE
04/16/10



CALIFORNIA HIGH-SPEED TRAIN PROJECT

COMPOSITE VEHICLE
STATIC AND DYNAMIC ENVELOPE
SUPERELEVATED TRACK

CONTRACT NO.
13259
DRAWING NO.
TM 1.1.10-C
SCALE
1/2"=1'-0"
SHEET NO.
3 OF 4

4/20/2010 10:19:07 AM T:\13259B Calif High Speed Rail\CADD\Directive Drawings\1.1.10 - Structure Gauge\1.1.10-D.dgn

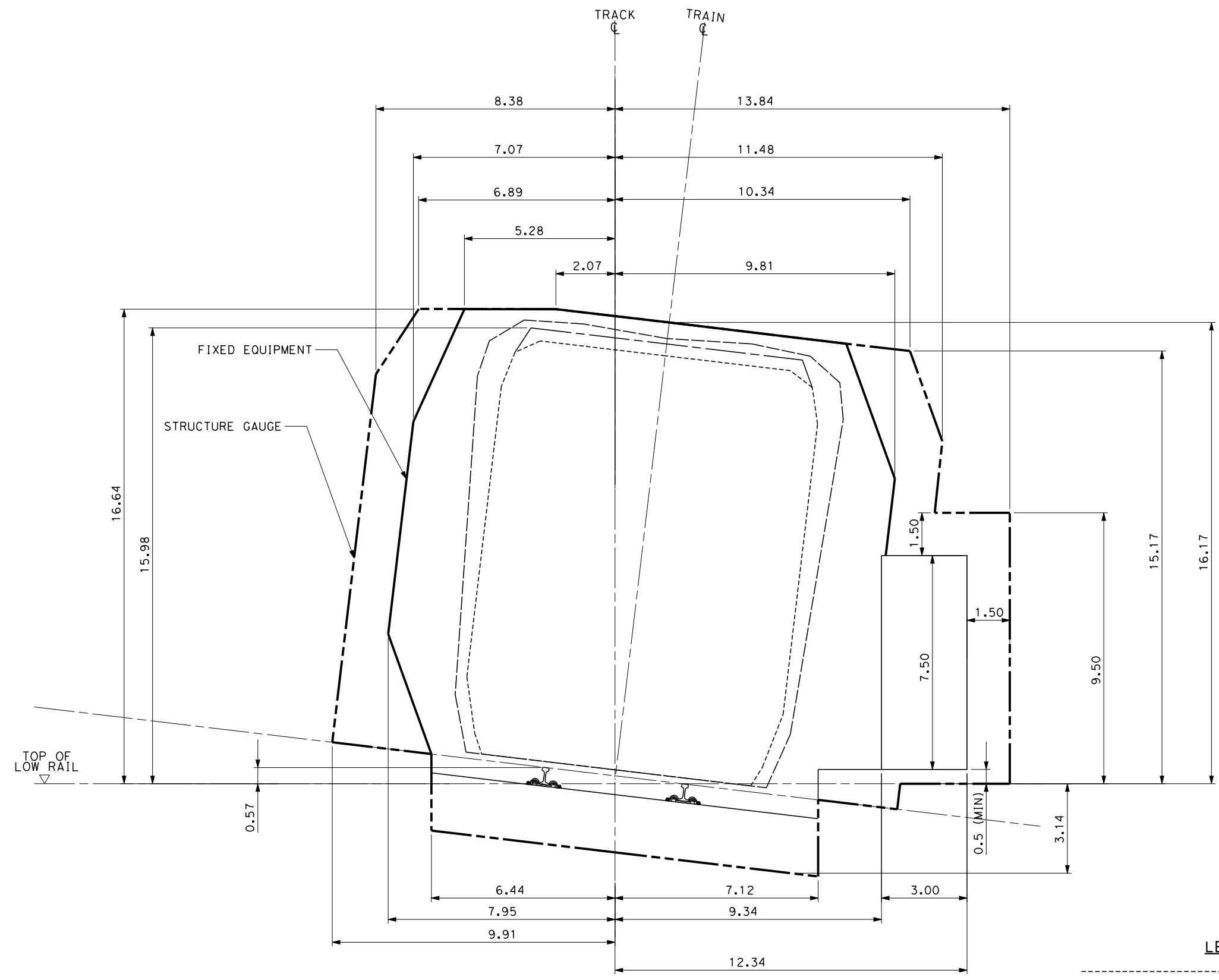

FIXED EQUIPMENT ENVELOPE AND STRUCTURE GAUGE

- NOTES OF ASSUMPTIONS**
1. NO ALLOWANCE FOR AERODYNAMICS
 2. EXCLUDES CONSTRUCTION TOLERANCES
 3. NO ALLOWANCE FOR VENT EQUIPMENT
 4. NOT AT STATIONS OR TUNNELS
 5. ALLOWANCE FOR OVERHEAD CATENARY SYSTEM NOT SHOWN.
 6. REFER TO TM 1.1.10 FOR ASSUMPTIONS
 7. HIGH-SPEED EQUIPMENT ONLY

LEGEND

- COMPOSITE STATIC ENVELOPE, EXCEPT TSI GC AT TOP
- TOP OF TSI GC STATIC ENVELOPE
- COMPOSITE DYNAMIC ENVELOPE
- FIXED EQUIPMENT ENVELOPE
- STRUCTURE GAUGE

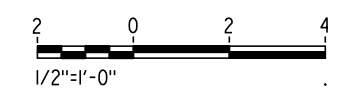

| REV | DATE | BY | CHK | APP | DESCRIPTION |
|-----|------|----|-----|-----|-------------|
| | | | | | |
| | | | | | |
| | | | | | |

DESIGNED BY
G. HARRIS
DRAWN BY
D. SOLTERO
CHECKED BY
J. THOMPSON
IN CHARGE
J. CHIRCO
DATE
04/16/10



CALIFORNIA HIGH-SPEED TRAIN PROJECT

COMPOSITE VEHICLE
FIXED EQUIPMENT ENVELOPE AND STRUCTURE GAUGE
SUPERELEVATED TRACK

CONTRACT NO.
13259
DRAWING NO.
TM 1.1.10-D
SCALE
1/2"=1'-0"
SHEET NO.
4 OF 4